

SMP DA-3050 automation platform



Contents

The SMP DA-3050 automation platform.....	1
General features.....	2
Cybersecurity.....	3
Benefits.....	3
System architecture and I/O features.....	4
Specifications.....	12
Certifications and compliance notes.....	23
Type test details.....	25
Temperature derating.....	33
Dimension drawings.....	35
Ordering information.....	40

The SMP DA-3050 automation platform

Description

The SMP DA-3050 is a compact automation platform with built-in I/O capabilities (controller) and optional stackable Input/Output modules for expansion needs; we offer four (4) factory-assembled models. The platform is Linux-based and can be installed on a DIN rail, on a rack or on a cabinet wall. A local HMI display* can be added to the device as an option (Capacitive touch TFT LCD).

The SMP DA-3050 automation platform is designed to be an open platform with support for containerized applications and custom development. It comes with the option of adding Input/Output modules (factory installed).

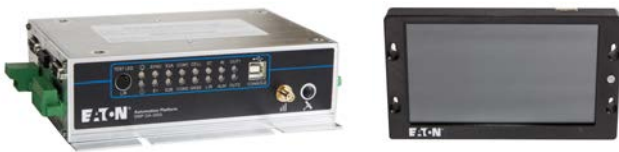

Figure 1: SMP DA-3050 model (controller only) and HMI display*



Figure 2: SMP DA-3051, SMP DA-3052 and SMP DA-3053 models

This compact and powerful automation platform with scalable I/O modules eliminates the need for extra I/O devices and provides essential secure communication and data concentration features. It is perfect for distributed automation, adding intelligent automation to passive grid edge systems. The added intelligence helps integrate back-end systems to provide visibility to events on the edge.

*: Features are coming soon

SMP Gateway automation platform

Eaton's SMP DA-3050 Linux-based automation platform is substation-grade; it is built on the latest SMP Gateway automation platform which has a proven history in data acquisition and distribution automation applications, as protocol conversion, data concentrator, DER controller and integration solution for secure IED remote access. It also provides scalable distributed I/Os capabilities to meet multiple requirements.

Eaton's SMP Gateway automation platforms are recognized as one of the most efficient and reliable automation platforms on the market and are perfect for substation and distributed automation.

The SMP DA-3050 platform

The SMP DA-3050 automation platform is specially designed to meet modern utility, industrial and commercial IoT requirements. We designed this automation platform to operate over a broad temperature range, which is critical in extreme environments. It is fully integrated with the SMP Tools software application and with the SMP Gateway Version Packs software for device configuration and maintenance.

The hardware layout of the controller (SMP DA-3050 model) has the same footprint as the SMP 4/DP automation platform, it can also be installed on a DIN rail to accommodate customers' needs which makes it perfect for a wall-mount installation in a confined space or in a cabinet.

The SMP DA-3050 automation platform uses a template-driven configuration tool, SMP Config, and includes numerous cybersecurity features to help utilities meet their compliance requirements, including NERC CIP. It is certified under UL 2900-1.

Cabinet installation

The SMP DA-3050 automation platform provides significant cost reduction by decreasing the amount of hardware in a distribution cabinet and combining multiple functions in the same product. Refer to our SMP DA-3050 automation platform with cabinet Catalog for details (CA912017EN, coming soon).

General features

Hardware

- Form factor: wall-mount, rack-mount or DIN rail-mount in an aluminum enclosure
- Conformal coating available as an option
- Individual LEDs for each I/O
- No moving parts
- Two built-in Form C relays for system alarm (on controller, configurable)
- 1 x built-in 24—48 Vdc digital input (on controller)
- 1 x built-in \pm 48 Vdc analog input (on controller)
- Integrated LTE cellular modem* CAT-M1/NB IoT
- GNSS* (option, hardware ready)
- System status LEDs
- Application LEDs
- Multifunction button (Local/Remote selector and Test LED)
- USB 2.0 console port (Type B port)
- Protected against polarity reversal for power supply
- Digital I/O module with 8 DI + 4 DO (on SMP DA-3051 and SMP DA-3052 and SMP DA-3053 models)
- Analog I/O module with 4 AI + 4 AO (on SMP DA-3052 model)

Protocols

Client protocols:

- IEEE 1815-2012 DNP3, IEC 61850 Ed.2*, IEC 61850 GOOSE, IEC 60870-5 101*/104*, Modbus, OPC UA*

Server protocols:

- IEEE 1815-2012 DNP3, IEC 61850 GOOSE, IEC 60870-5 101*/104, Modbus*, OPC UA*

Communication and web/local interfaces

- 2 x RS 232/485 2-wire serial interface with IRIG-B distribution*
- CAT-M1 / NB IoT cellular modem*
- 1 x 10/100/1000 Mb/s SFP-based metallic* or 100B-FX or 1000B-LX LC optical Ethernet port
- 2 x 10/100Base-T metallic Ethernet ports (behind switch)
- Web interface for real-time values and alarms
- Optional Local HMI interface* on a high resolution TFT LCD display (1024 x 600) with capacitive touch support (coming soon)
- Secured remote maintenance using transparent connection* (SMP Gateway and IMS passthrough)

Software

- Linux®-based operating system
- Enable containerized customer applications*
- Access to SMP Tools
- Remote management (firmware upgrade, setting changes, license update)
- Configuration with SMP Config, multi- protocols/ instances, configurable point mapping
- Offline and template-driven configuration
- Built-in Automation Functions for local simple programmable logic
- Built-in SoftPLC engine IEC 61131-3 (CODESYS)* for local advanced programmable logic
- Centralized management via Enterprise Management Software (IMS)*
- System alarms

Mapping

- Predefined and custom mappings
- Serial number, version, internal status, current time, last reset time and more are available in the protocol mapping
- Exportable DNP XML device profile

System

- Integrated self-diagnostics
- Integrated watchdog timer
- Real-time clock (with battery backup)
- Internal clock synchronization using unmodulated IRIG-B*, SNTP*, GNSS* (option, synchronization and positioning) or via DNP3, IEC-60870-5-104 protocols
- Time distribution using unmodulated IRIG-B*, SNTP or via DNP3 protocol
- Local/Remote switching mechanism and state (logical points)
- Logs support (Security, System, and others)

*: Features are coming soon

Cybersecurity

- CPU Secure Boot ensures that the software loaded at power-on is trusted
- UL 2900-1 compliant for version 1 release: Standard for Software Cybersecurity for Network-Connectable Devices
- Implement DNP3 secure authentication V2* and V5* as per IEC 62351-5
- IEEE 1686 compliance
- Local/Global* (IMS) security
- Smart firewall
- Ability to disable any unused port (report enabled-disabled ports)
- Secure maintenance connection (TLS) via SMP Gateway Passthrough* or via direct SMP Manager connection*
- Secure USB maintenance port (Console port)
- Secure command shell
- Access management (log, lockup, etc.)
- Account management:
 - Strong passwords
 - User accounts and user groups
 - Detailed group permissions
- All system components digitally signed
- Digital signature validated before using the system
- Factory reset in case of Admin password loss

Benefits

With its robust and scalable design, Eaton's SMP DA-3050 automation platform is flexible and adapts to evolving automation requirements.

Reliability

- Designed to evolve through regular software and firmware updates, ensuring a future-proof automation system
- Helps meet NERC CIP requirements by securing IED remote access* and enhancing SCADA communication links

Scalability

- Optional stackable I/O modules to fit the needs of various utility, industrial and commercial automation applications
- Software configurable voltage ranges on digital inputs

Easy integration

- Complete support for the SMP Tools
- Easy configuration using SMP Config
- Simplified pre-loading operation of existing configuration into the automation platform prior to installation

Productivity

- Offline configuration tools
- Web interface for real-time I/O, alarms, communications and more
- Enhanced automation capabilities using the IEC 61131-3 SoftPLC (CODESYS)*

System architecture and I/O features

The SMP DA-3050 automation platform comes pre-loaded with I/Os specific to the selected model.

An overview of the I/O capabilities of both the basic unit and I/O expansion modules are presented below.

I/Os on Controller (basic unit)

- 1x 24 — 48 Vdc DI (Follows input supply voltage)
- 2x Alarm contacts DO (2x FORM C relay contacts, configurable as Trip/Close pair, Pulse, Local/Remote operation mode)
- 1x ± 48 Vdc AI

Analog inputs (Analog I/O module)

- Voltage and current inputs
- ±10 V, ±1 mA, ±2 mA, ±20 mA software-selectable mode and range
- Resolution of 16-bits+sign
- High/Low warning support
- Deadband, scaling and units
- User calibration at fixed ambient temperature

Digital outputs (Digital I/O module)

- Output protection against single component failure
- Trip/close pair, latch, pulse and pulse pair support
- Pulse train command support
- Persisted operation counter
- Digital points software polarity reversal
- Control queuing allows up to 10 parallel requests, sequentially processed when the same point is targeted

Digital inputs (Digital I/O module)

- AC and DC inputs
- 24—48 V, 125 V
- Software-selectable range
- Tolerance/Intolerance filtering
- Chatter protection
- Fail safe circuit (active level in normal state)
- Digital points software polarity reversal
- Timetag at the beginning or end of the filtering (software-configurable)
- Persisted counters (total transitions, up/down direction), with deadband, scaling and roll over detection
- Freeze, clear, freeze and clear counters support

Analog outputs (Analog I/O module)

- Voltage and current outputs
- ±10 V, ±20 mA software-selectable mode
- Self-sourcing outputs (cannot be used in a loop-powered setup)
- High-impedance output for redundancy applications
- Resolution of 12 bits

Table 1: Modular configuration provides four (4) models based on the following modules

Module type	Additional notes
Controller module (minimal configuration)	Basic module that is available on all four models. 1 x 24 — 48 Vdc DI 2 x alarm contact DO (FORM C) 1 x ± 48 Vdc AI
Digital I/O module 8DI — 4DO	Expansion module type that is available on the following models: <ul style="list-style-type: none"> • SMP DA-3051 (Controller + 1 Digital I/O module) • SMP DA-3052 (Controller + 2 Digital I/O modules + 1 Analog I/O module) • SMP DA-3053 (Controller + 3 Digital I/O modules) DI: ± 24 Vac/dc—48 Vac/dc, ± 125 Vac/dc (software selectable) DO: Form C relays (all DO# odd), Form A relays (all DO# even)
Analog I/O module 4AI — 4AO	Expansion module type that is available on the SMP DA-3052 model (Controller + 2 Digital I/O modules + 1 Analog I/O module) AI: 4 x ±10 V, ±20 mA, ±2 mA, ±1 mA software selectable 16-bits (including sign) analog inputs AO: 4 x ±10 V, ±20 mA, software selectable 12-bits analog outputs

Table 2: Available options

Type and option	Additional notes
Cellular modem*	LTE CAT-M1 / NB IoT cellular modem with worldwide coverage. Supports Micro-SIM 3FF sized card from your operator of choice.
TFT LCD with capacitive touch*	1024 x 600 @ 60Hz TFT LCD with capacitive touch screen and configurable backlight.
GNSS* (hardware ready) (satellite-synchronized clock)	<p>Hardware ready with the basic unit, antenna must be bought separately (Eaton's sells one recommended antenna; other compatible antennas are supported). Global multi-constellation navigation satellite system, supports GPS, Galileo, Glonass, BeiDou and QZSS constellations.</p> <p>Note: Contact us if you are interested to buy the GNSS option.</p>

Component identification on the unit

This section describes the front, left and right-side panels of the of the SMP DA-3050 automation platform, all main components are identified.



Figure 3: Front view (the SMP DA-3053 model is shown)

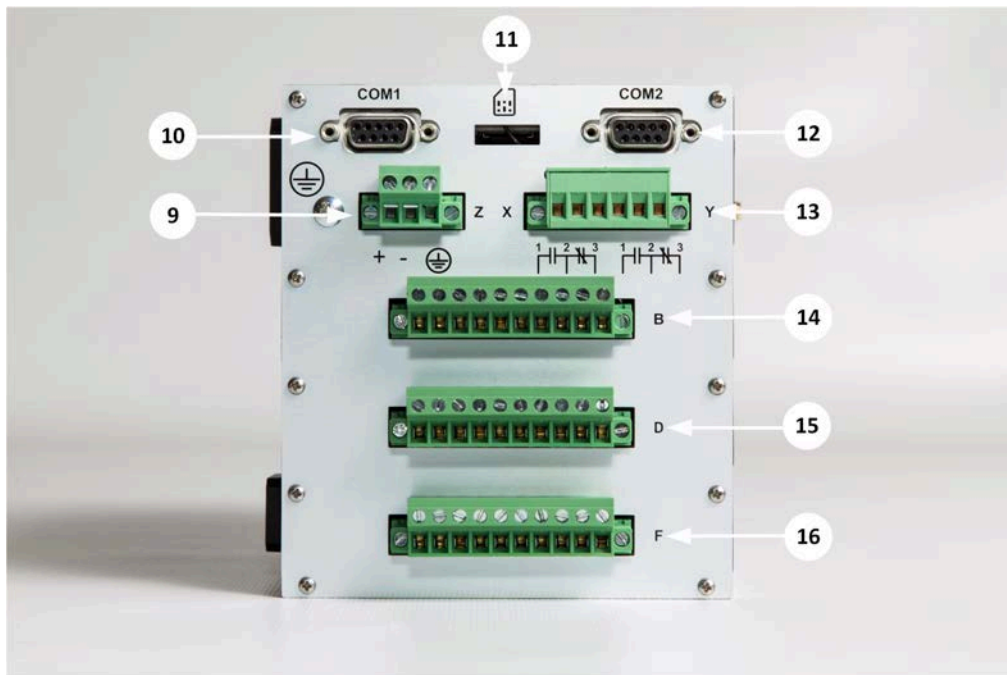

Figure 4: Left view (the SMP DA-3052 or SMP DA-3053 model is shown, identical on the left side)

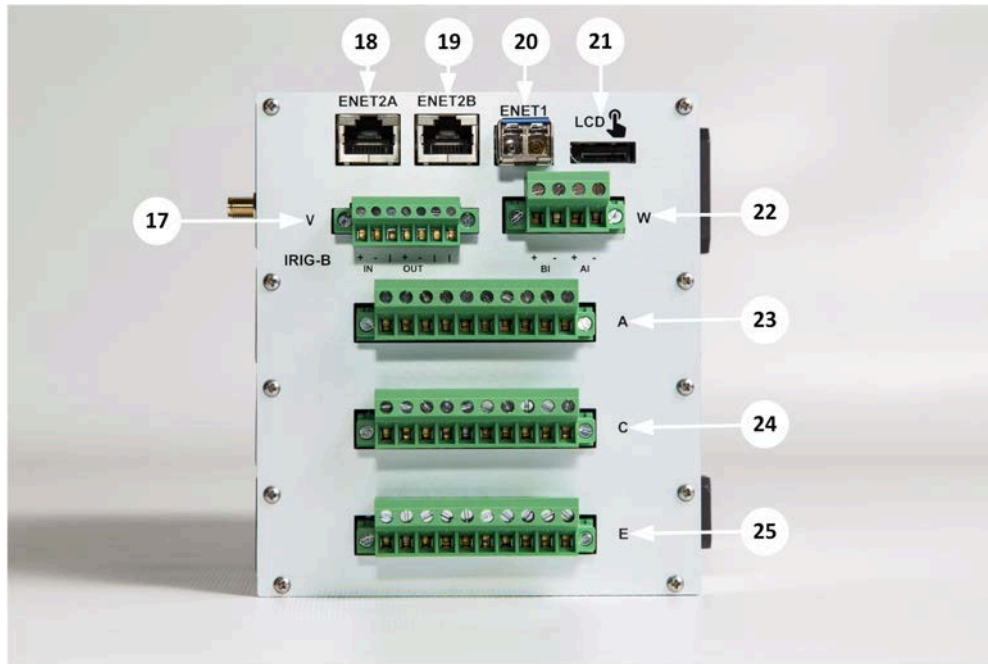

Figure 5: Right view (the SMP DA-3052 or SMP DA-3053 model is shown, identical on the right side)

The following table describes components of the front, left and right-side panel of the of the SMP DA-3050 automation platform according to the previous figures:

Note: The terms Binary Input (BI) and Digital Input (DI) are equivalent, the same apply with BO and DO.

Table 3: Components of the SMP DA-3050

#	ID	Description
1	Test LED or Local/Remote (L/R) push button	<p>Multi-function button used to:</p> <ul style="list-style-type: none"> • Test the front panel LEDs. When pressed, these LEDs should illuminate: <ul style="list-style-type: none"> - OUT1, OUT2, BI, ALM - All I/Os from I/O modules (BI, BO, AI, AO) - ST, L/R, SYNC - E1, E2A, E2B - Watchdog, COM1, COM2 - CELL, GNSS (option) • Switch the operation between Local and Remote operation. To do so, press and hold the button during the first five (5) seconds during steady operation of the device (boot-up sequence must be terminated), until the LEDs light up. The SMP DA-3050 will then switch between Local and Remote modes. The current mode is shown on the L/R LED (blinks in local mode). • Force the system to boot into rescue mode. To do so, press and hold the button during the first five (5) seconds during the boot-up sequence, until the LEDs light up. The SMP DA-3050 will then boot in rescue mode.

Table 3: Components of the SMP DA-3050

#	ID	Description
2	System status LEDs	<p>Power: This LED indicates the status of the internal power supply. Additional information about the power supply is also available using the SMP Stats program.</p> <p>Watchdog: Watchdog timer status LED.</p> <p>SYNC: Clock synchronization LED. This LED indicates the synchronization status of the SMP DA-3050 connected to an IRIG-B synchronization source.</p> <p>E1/E2A/E2B port activity: Built-in ENET1, ENET2A and ENET2B port activity LEDs. The two ENET2 ports are used as Ethernet switches for daisy-chain connections. Each LED indicates the speed and activity level of the corresponding Ethernet port (switch).</p> <p>COM1/ COM2: Serial port activity LED.</p> <p>ST: Status LED. This LED indicates the various steps the SMP DA-3050 goes through during the startup sequence.</p> <p>L/R: Local / Remote control status LED. The local/remote interlock mechanism is a safety measure which totally disables the operation of control outputs when set to Local.</p> <p>CELL: Cellular modem status LED.</p> <p>GNSS: GNSS synchronization LED. This LED indicates the synchronization status of the SMP DA-3050 connected to an GNSS constellation as a synchronization source (option, hardware ready).</p> <p>BI: Digital input status LED (for BI (DI) on controller)</p> <p>ALM: Alarm status LED.</p> <p>OUT1/OUT2: Relay status LED (for OUT1 and OUT2 on controller).</p>
3	CONSOLE port	Type-B USB 2.0 port. This port is used for maintenance and configuration of the SMP DA-3050; it is always enabled.
4	Cellular antenna port	Female SMA connector for cellular antenna.
5	GNSS antenna port	(option, hardware ready) Female SMA connector for active GNSS antenna
6	I/O expansion module #1 status LEDs	Digital I/O module: <ul style="list-style-type: none"> • One LED per DI, DI[x] status reported on the LED[x] • One LED per DO, DO[y] status reported on the LED[y]
7	I/O expansion module #2 status LEDs	Digital I/O module: <ul style="list-style-type: none"> • One LED per DI, BI[x] status reported on the LED[x] • One LED per DO, DO[y] status reported on the LED[y]
8	I/O expansion module #3 status LEDs	If digital I/O module: <ul style="list-style-type: none"> • One LED per DI, DI[x] status reported on the LED[x] • One LED per DO, DO[y] status reported on the LED[y] If analog I/O module: <ul style="list-style-type: none"> • One LED per AI, AI[x] status reported on the LED[x] • One LED per AO, AO[y] status reported on the LED[y]

Table 3: Components of the SMP DA-3050

#	ID	Description
9	PWR Power supply Terminal block (Z)	Wiring terminals for the power supply. Accepts an input range of 24—48 Vdc Eaton recommends the use of a shielded cable with 18 to 12 AWG wires for the terminal block used for the power supply. Note: If the SMP DA-3050 is intended for use at ambient temperatures greater than 140 °F (60 °C), use a cable with a suitable temperature rating. Recommended torque for this terminal block is 0.5 N m (4.4 lbf in).
10	RS 232/485 serial COM1	DB9 (DE9) universal serial (COM1) <ul style="list-style-type: none"> • RS 232 with full modem signals (TX, RX, RTS, CTS, DSR, DTR, DCD, RI) • 2-wire RS 485 support (multidrop*) • Up to 1200 m (4000 ft.) • Up to 32 devices (multidrop)* • Baud rates supported on this port: 300, 600, 1200, 2400, 4800, 9600, 19200, 38400, 57600, 115200 bps • IRIG-B distribution*
11	Cellular modem SIM card slot	SIM card entry slot for the embedded CAT-M1 / NB IoT LTE Modem. SIM size is MicroSIM-3FF.
12	RS 232/485 serial COM2	DB9 (DE9) universal serial (COM2) <ul style="list-style-type: none"> • RS 232 with full modem signals (TX, RX, RTS, CTS, DSR, DTR, DCD, RI) • 2-wire RS 485 support (multidrop*) • Up to 1200 m (4000 ft.) • Up to 32 devices (multidrop)* • Baud rates supported on this port: 300, 600, 1200, 2400, 4800, 9600, 19200, 38400, 57600, 115200 bps • IRIG-B distribution*
13	Controller BO (OUT1/2) Terminal block (X - Y)	Terminal block Dual Form C relay terminals (up to 8 A max): NO / COM / NC OUT1 relay's NC contact is pre-configured for system health monitoring (application). Both relays are available for system applications and can be activated through a system data output point, if configured. When configured for system health monitoring, the OUT1 relay's NC contact operates as follows: The relay's NC contact remains closed (off) until the SMP DA-3050 is started. Thereafter, the contact is opened (on) if the SMP DA-3050 is working properly. In case of failure, the NC contact closes.
14	I/O expansion module #1 Terminal block (B)	Digital I/O module: 2 x Form C and 2 x Form A relay output
15	I/O expansion module #2 Terminal block (D)	Digital I/O module: 2x Form C and 2x Form A relay output
16	I/O expansion module #3 Terminal block (F)	If digital I/O module: 2x Form C and 2x Form A relay output If analog I/O module: 4x Bipolar analog input + shield

Table 3: Components of the SMP DA-3050

#	ID	Description
17	IRIG-B IN/OUT terminal block (V)	IRIG-B input and output connector
18	ENET2A port	Controller Ethernet connectors (switch). Both connectors are of the same type. The following connector types are available for these ports: <ul style="list-style-type: none"> • Shielded metallic RJ45 (standard) • Supports 10/100 Mbps CU
19	ENET2B port	Controller Ethernet connectors (switch). Both connectors are of the same type. The following connector types are available for these ports: <ul style="list-style-type: none"> • Shielded metallic RJ45 (standard) • Supports 10/100 Mbps CU
20	ENET1 port	SFP-based Ethernet connector Supports SFP transceivers 10/100/1000 Mbps CU* and SFP 100/1000 Mbps LC (FX, LX)
21	HMI Display port connector	Physical connection to an optional Capacitive touch TFT LCD for HMI Display
22	Controller DI / AI Terminal block (W)	Controller I/O terminal block. <ul style="list-style-type: none"> • Single 24—48 Vdc binary input (follows input power supply) • Single \pm 48 Vdc analog input
23	I/O expansion module #1 Terminal block (A)	Digital I/O module: 8x Binary inputs
24	I/O expansion module #2 Terminal block (C)	Digital I/O module: 8x Binary inputs
25	I/O expansion module #3 Terminal block (E)	If digital I/O module: 8x Binary inputs If analog I/O module: 4x Bipolar analog output + shield

Pinout of connectors

This section displays the pinout of all the connectors on the SMP DA-3050 automation platform.

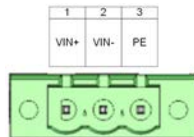

Figure 6: Controller — Power input pinout

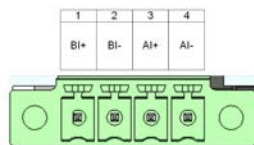

Figure 7: Controller — AI / BI (DI) pinout

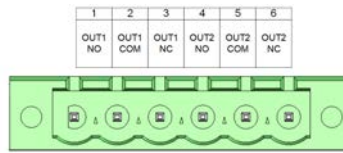

Figure 8: Controller — BO (DO) pinout

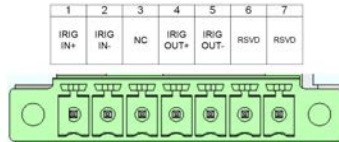

Figure 9: Controller — IRIG IN/OUT pinout

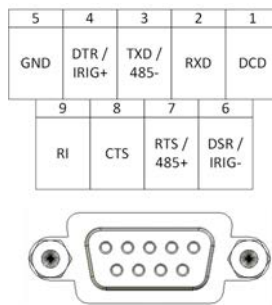

Figure 10: Controller — RS 232/RS 485/ IRIG-B out COM pinout

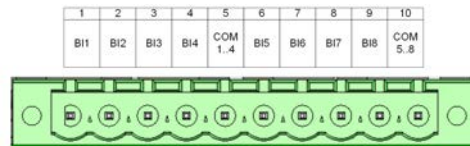

Figure 11: Digital I/O module — BI (DI) pinout

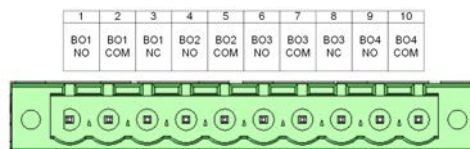

Figure 12: Digital I/O module — BO (DO) pinout

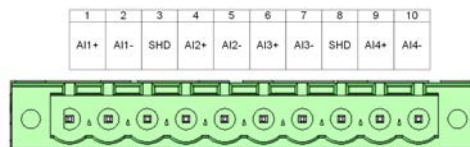

Figure 13: Analog I/O module — AI pinout

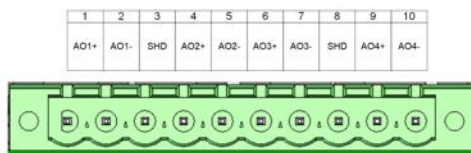

Figure 14: Analog I/O module — AO pinout

Note: RSVD means reserved and NC means not connected.

Specifications

Important: The SMP DA-3050 automation platform is currently undergoing tests for the different component specifications listed in this section. The values are subject to change until the testing phase has been completed.

In this document, the * is placed next to features that are not yet available. Those features are coming soon.

Specifications — General and Communication

Table 4: General specifications

General specifications		
Dimensions		
Controller (SMP DA-3050 model)	Height: 1.94 in. (49.2 mm) Width: 4.5 in. (114.3 mm) Depth: 6.5 in. (165.1 mm) 2.2 lb max (1 kg)	Connectors on front, left and right panels.
Controller with 1 I/O module (SMP DA-3051 model)	Height: 2.97 in. (75.4 mm) 3.1 lb max (1.4 kg)	Width and depth values are the same as for the SMP DA-3050 model.
Controller with 3 I/O modules (SMP DA-3052 and SMP DA-3053 models)	Height: 5.12 in. (130 mm) 4.2 lb max (1.9 kg)	
Installation	Wall-mount, rack-mount or DIN-rail installation	All 3 installation options come with an installation kit (see section Ordering information).
Warranty	10-year limited	
Operating temperature	-40 °F to +167 °F 1 (-40 °C to 75 °C)	1 : cTUVus safety marking is based on the temperature table.
Storage temperature	-40 °F to +185 °F (-40 °C to 85 °C)	
Humidity	5 to 95%, non-condensing	
Degrees of protection provided by enclosure	IP30 (design to meet)	IEC60529: 2013

Table 4: General specifications

General specifications		
MTBF	Theoretical: <ul style="list-style-type: none"> • 14.7 years @ 40 °C • 23.4 years @ 25 °C 	The Reliability prediction report is available on demand.
	Real MTBF : > 272 years	The MTBF value is obtained from the ratio of the number of devices in operation over the actual number of failures observed on devices of the same SMP family.
Maximum altitude	Up to 6561.7 feet (2000 meters)	
Real-time clock (with battery backup)	<ul style="list-style-type: none"> • Drift: ± 3 sec/day on normal operating temperature range and ± 20 sec/day outside the operating temperature range. • Nominal accuracy of 100 us • Rechargeable battery backup, 20 years shelf life 	Not serviceable Battery autonomy > 20 days Battery charging time < 8 hrs

Table 5: Power supply specifications

Power supply specifications		
<p>Note: The power cable is not shipped with the device. The cable must be ordered separately or supplied by the customer. Refer to section Accessories and Cables options for details about the power cable.</p>		
Specifications		
Nominal voltages	24, 48 Vdc	
Input voltage range	19.2—60 Vdc	
Inrush current	24 Vdc: 22 A < 0.5 ms 48 Vdc: 45 A < 0.5 ms	
Short interruption	24 Vdc: 6 ms 48 Vdc: 40 ms	Typical load, controller only @ 25 °C
Power consumption	SMP DA-3050 (controller only): 6.8 W SMP DA-3051 model: 8.5 W SMP DA-3052 model: 15.42 W SMP DA-3053 model: 11.2 W Cell: 0.9 W TFT display: 5 W	Estimated values representing worst-case scenarios
Isolation		

Table 5: Power supply specifications

Power supply specifications		
Protection	3.15 A fuses on both lines 4.2 J differential MOV Reverse polarity protection	
Dielectric	1500 Vdc	
Terminal block power	3-pin connector	Located on the bottom left side
Wire size	12—30 AWG solid wire 12—30 AWG stranded wire	
Wire screw max torque	5.3 lb-in (0.6 N-m)	

Table 6: Auxiliary port

Auxiliary port		
USB		
USB 2.0 client (CONSOLE)	Type B connector (front panel)	

Table 7: Communication ports Ethernet

Ethernet communication ports		
Ethernet 1 : One (1) port, LED indicator on front panel.		
Metallic connectors, SFP*	1 x 10/100/1000BASE-T	RJ-45 connector
Fiber-optic, SFP	1 x 100BASE-FX, up to 2 km 1 x 1000BASE-LX, up to 40 km	LC connector Multimode 1310 nm LC connector Multimode 850 nm (550 m) or 1310 nm (10 or 40 km)
Ethernet 2 A/B Two (2) ports, LED indicator on front panel. Both connectors of the built-in Ethernet ports are of the same type.		
Metallic connectors (standard)	2 x 10/100/BASE-T/TX	RJ-45 connector
Protection	1500 Vrms dielectric	

Table 8: Serial communication port

Serial communication port		
Feature	2-wire RS 232/485 support (multidrop*) Up to 1200 m (4000 ft.) 32 devices* and 115200 b/s IRIG-B distribution* configurable by software	
Protection	Common mode TVS	40 W, 1 ms
Wire size	16—28 AWG	
Wire screw max torque	2.2 lb-in (0.25 N-m)	

Table 9: Cellular modem*

Cellular modem CAT-M1 / NB IoT	
Processor architecture	ARM
Supported LTE bands	LTE-FDD: B1[2100], B2[1900] B3[1800], B4[1700], B5[850], B8[900], B12[700], B13[700], B18[850], B19[850], B20[800], B25[1900], B26[850], B27[850], B28[700], B66[1700], B71[600], B85[700]
Coverage	Worldwide
SIM card size	3FF Micro-SIM (Interchangeable)
Secure Boot	Yes
Throughput	LTE-M1: Download = 588 Kbps, Upload = 1 Mbps NB-IoT: Download = 120 Kbps, Upload = 160 Kbps
Maximum RF output power	4G LTE M1, NB2: 23 dBm (Class 3) 2G GSM/GPRS: 33 dBm (Class 4)

Table 10: IRIG-B time synchronization* and distribution*

Time synchronization and distribution		
Unmodulated IRIG-B input		
Input	Via terminal block	Isolated
	2 V high-level detection	Current sink at 5 V IRIG-B 5 mA Current sink at 10 V IRIG-B; 11 mA
	Vin max up to 12 VDC, Opto-isolated IEEE 1344, C37.118, B002, B003, B004, B006, B007	Input impedance = 1000 Ω \pm 10%
Protection	Accuracy: \pm 100 μ s	

Table 10: IRIG-B time synchronization* and distribution*

Time synchronization and distribution			
		Differential mode TVS	
		2000 Vrms dielectric	
Terminal block IRIG-B		7-pin connector	
	Wire size	16—28 AWG	
	Wire screw max torque	2.2 lb-in (0.25 N-m)	
Unmodulated IRIG-B output			
	Output	Via dedicated terminal block and COM1, COM2 serial ports	Not isolated Max load: 50 Ω
	Protection	Up to 10 IEDs load on IRIG-B output No isolation, TVS protection	

Table 11: HMI Display*

HMI Display	
Size	7 in. diagonal
Type	IPS TFT LCD
Resolution	1024 x 600 pixels
Touch screen type	Industrial capacitive multi-touch panel (up to 10 x simultaneous touch points)
Video interface	LVDS (Low Voltage Differential Signaling)
Brightness	800 cd/m ² , software adjustable
Connectivity	Custom DisplayPort (DP) interface Important: The video interface is only compatible with Eaton's HMI display. It is non-compliant with video interfaces of generic/off the shelf devices (non-destructive behavior).
Operating temperature	-4 °F to + 158 °F (-20 °C to 70 °C)
Storage temperature	-22 °F to + 176 °F (-30 °C to 80 °C)

Table 12: GNSS time synchronization*

GNSS (optional, hardware ready)	
Note: Contact us if you are interested to buy the GNSS option.	
Processor architecture	TESEO-LIV3F
Supported constellations	GPS, Galileo, Glonass, BeiDou and QZSS constellations
Antenna	Active antenna only

Table 13: CPU

CPU	
Processor architecture	ARM
Operating system	LINUX
Processor	1.6 GHz Quad-core
Memory	8 Gigabits NAND Flash, 1 or 4 Gigabits LP-DDR4 RAM
Secure Boot	Yes

Specifications — Controller I/Os

Table 14: Controller — Auxiliary relays (alarm relays)

Auxiliary relays (alarm relays)		
2 Form C relays (OUT1, OUT2)	Normally open and normally closed relays contacts (NO/NC) First relay is pre-configured for system health monitoring. Both relays are available for system applications and can be activated through a system data point.	The relays designed to meet the following specifications: <ul style="list-style-type: none"> • 150 W / 2000 VA (max power) • 125 Vdc / 120 Vac (max voltage) • 8 A (max interruption current) • 8 A (max carrying current)
Isolation		
Protection	300 Vac / 385 Vdc, 23 J MOV protection across contacts	
Dielectric	2500 Vrms	
Terminal block Auxiliary relays	6-pin connector	2 Form C contacts
Wire size	12—30 AWG solid wire 12—30 AWG stranded wire	
Wire screw minimum torque	4.4 lb-in (0.5 N-m)	
Wire screw maximum torque	5.3 lb-in (0.6 N-m)	

Table 15: Controller — Status and alarm inputs (digital inputs)

Status and alarm inputs (digital inputs)		
Voltage range		
± 24 Vdc—48 Vdc		ON > ± 14 Vdc; OFF <± 8 Vdc Max voltage input: ± 60 Vdc
Current draw at nominal		
± 24 Vdc		3.6 mA

Table 15: Controller — Status and alarm inputs (digital inputs)

Status and alarm inputs (digital inputs)		
	± 48 Vdc	7.7 mA
Sampling rate	500 µs	
Debouncer delay	Software configurable up to 127 ms	No hardware filter
Isolation		
Protection	Protection across contacts: 64 Vdc, 1500 W TVS	
Dielectric	2500 Vrms	
Terminal block binary input		
Wire size	12—30 AWG, solid/stranded wire	
Wire screw minimum torque	4.4 lb-in (0.5 N-m)	
Wire screw maximum torque	5.3 lb-in (0.6 N-m)	

Table 16: Controller — Analog inputs

Analog inputs		
Input range		
Operation mode	Voltage mode only	Not software-configurable
Dynamic range	120%	
Voltage mode	± 48 V	Max voltage input: ± 70 Vdc
Input impedance		
Voltage mode	12 MΩ ±5%	± 10 V
Resolution	16 Bits + sign	
Accuracy		
Voltage mode	± 0.05 % of full scale @ 25 °C	Factory calibrated (@ 25 °C)
Accuracy variation	± 0.0015 % / °C of full scale @ 25 °C	
Isolation		
Protection	Protection across contacts: 64 Vdc, 1500 W TVS	
Dielectric	1500 Vrms, all analog inputs to protective earth	
Common Mode Rejection DC (CMR)	> 90 dB	

Table 16: Controller — Analog inputs

Analog inputs		
Sampling rate	200 ms	
Terminal Block Analog Inputs		
Wire size	12—30 AWG, solid/stranded wire	
Wire screw minimum torque	4.4 lb-in (0.5 N-m)	
Wire screw maximum torque	5.3 lb-in (0.6 N-m)	

Specifications — Digital I/O module

Table 17: Digital I/O module — Status and alarm inputs (digital inputs)

Status and alarm inputs (digital inputs)		
Voltage range (selectable by software)		
± 24 Vdc—48 Vdc		ON > ± 19 Vdc; OFF <± 15 Vdc Max voltage input: ±150 Vdc
± 125 Vdc		ON > ± 80 Vdc; OFF <± 65 Vdc Max voltage input: ±150 Vdc
Current draw at nominal		
± 24 Vdc—48 Vdc		1.9 mA
± 125 Vdc		2.25 mA
Sampling rate	500 μs	
Debouncer delay	Software configurable up to 127 ms	No hardware filter
Isolation		
Protection	Protection contact group to ground: 130 Vac / 170 Vdc 9.5 J MOV	
Dielectric	2500 Vrms	
Terminal block digital input		
Wire size	12—30 AWG	
Wire screw maximum torque	4 lb-in (0.44 N-m)	

Table 18: Digital I/O module — Control outputs (relays)

Control outputs (relays)		
Output relays	Form C relays (all BO # odd) Form A relays (all BO # even)	
Isolation		
Protection	300 Vac / 385 Vdc, 23 J MOV Protection across contacts	
Dielectric	2500 Vrms	
Operating time	Pickup 10 ms maximum Dropout 6 ms maximum	@ 20 °C, excluding bouncing
Relay rating Form C		
Rated load	5 A at 30 Vdc resistive 8 A at 120 Vac resistive 0.4 A at 125 Vdc resistive 3 A at 120 Vac $\cos\phi=0.7$ 1/3 HP at 120 Vac	
Max switching power	150 W / 2000 VA	
Rated insulation voltage	250 Vrms	
Maximum switching voltage	125 Vdc / 120 Vac	
Continuous carry	8 A at 25 °C 5 A at 75 °C	
Continuous carry AC/DC UL/CSA derating	5 A at < 60 °C 2.5 A between 60 °C and 70 °C	
Minimum load	10 mA, 5 Vdc	All relay types
Make and carry per IEEE-C37.90.2005	30 A	
Cycling capacity (1 cycle/second) per IEC 60255-0-20:1974	24 Vdc / 0.8 A L/R=40 ms 48 Vdc / 0.5 A L/R=40 ms 125 Vdc / 0.3 A L/R=40 ms	
Breaking capacity (10,000 operations) per IEC 60255-0-20:1974	24 Vdc / 0.8 A L/R=40 ms 48 Vdc / 0.5 A L/R=40 ms 125 Vdc / 0.3 A L/R=40 ms	
Short Time Thermal Withstand per IEC 60255-0-20:1974	50 A for 1 second	
Terminal Block Binary Output		
Wire size	12—30 AWG solid/stranded wire	
Wire screw minimum torque	4.6 lb-in (0.5 N-m)	

Table 18: Digital I/O module — Control outputs (relays)

Control outputs (relays)		
Wire screw maximum torque	5.3 lb-in (0.6 N-m)	

Note: For the Normally Closed (NC) contacts of the Form C relays, the output value may encounter small variations during vibration events. This will not trigger status or alarm inputs.

Specifications — Analog I/O module

Table 19: Analog I/O module — Analog inputs

Analog inputs				
Input range				
Operation mode	Voltage and current modes			
Dynamic range	120%			
Voltage mode	± 10 V	Software configurable, input resistors are implemented on PCB		
Maximum voltage input	± 13 V			
Current mode	± 20 mA (4—20 mA transducers)			
	± 2 mA (0—1 mA transducers), overrange capabilities			
	± 1 mA (0—1 mA transducers)			
Input impedance				
Voltage mode	$12\text{ M}\Omega \pm 5\%$	± 10 V		
Current mode	$500\ \Omega$	± 20 mA		
	$5\text{ k}\Omega$	± 2 mA		
	$10\text{ k}\Omega$	± 1 mA		
Resolution	16 Bits + sign			
Accuracy				
Voltage mode	$\pm 0.02\%$ of full scale @ 25 °C	Factory calibrated (@ 25 °C)		
Current mode	$\pm 0.05\%$ of full scale @ 25 °C			
Accuracy variation	$\pm 0.0015\%$ / °C of full scale @ 25 °C			
Isolation				
Protection	Differential TVS protection: 12 Vdc, 400 W			

Table 19: Analog I/O module — Analog inputs

Analog inputs		
Dielectric	1500 Vrms channel to channel 1500 Vrms, channel to protective earth	
Common Mode Rejection DC (CMR)	> 90 dB	
Sampling rate	200 ms	
Terminal Block Analog Inputs		
Wire size	12—30 AWG solid wire	
Wire screw maximum torque	5.3 lb-in (0.6 N-m)	

Table 20: Analog I/O module — Analog outputs

Analog outputs		
Output range		
Voltage mode	$\pm 10\text{ V} + 15\%$ overrange	Voltage and current modes are software configurable.
Current mode	$\pm 20\text{ mA} + 5\%$ overrange (4—20 mA transducers) Self-powered current outputs	
Max voltage output	$\pm 11.5\text{ V}$	
Max current output	$\pm 21\text{ mA}$	
Load impedance		
Voltage mode	$\geq 2000\ \Omega$, 100 nF	Over full range
Current mode	$\leq 750\ \Omega$	Over full range
Resolution	12 Bits (including sign)	
Step response		
Voltage mode	$\leq 500\ \mu\text{s}$ (10-90% typical response)	
Current mode	$\leq 500\ \mu\text{s}$ (10-90% typical response)	
Accuracy		
Voltage mode	$\pm 0.2\%$ of full scale @ 25°C	Factory calibrated (@ 25 °C)
Current mode	$\pm 0.2\%$ of full scale @ 25°C	
Accuracy variation	$\pm 0.004\%/^{\circ}\text{C}$ of full scale	
Isolation		

Table 20: Analog I/O module — Analog outputs

Analog outputs		
Protection	Differential TVS protection: 18 Vdc, 400 W	
Dielectric	1500 Vrms channel to channel 1500 Vrms channel to protective earth	
Terminal Block Analog Inputs		
Wire size	12—30 AWG solid wire	
Wire screw minimum torque	4.4 lb-in (0.5 N-m)	
Wire screw maximum torque	5.3 lb-in (0.6 N-m)	

Certifications and compliance notes

The SMP DA-3050 automation platform was developed under rigorous design requirements and meets or exceeds the standards that were required.

Note: The SMP DA-3050 automation platform is presently undergoing testing for the certification and compliance requirements. Until we get all test results, several certification and standard compliance may remain undetermined or are subject to change.

Table 21: SMP DA-3050 certification and standard compliance

Certification	Notes
cTUVus Marking	Tests in progress
ISO 9001:2008	The SMP DA-3050 design and manufacturing processes are executed under the supervision of a Quality Management System that meets the requirements of the ISO 9001 standard. ISO 9001:2008 certificate of conformance was awarded by an independent certification authority. The corresponding certificate, quality manual and quality policy are available on demand.
RoHS	2002/95/EC (in progress)
REACH	Regulation (EC) No 1907/2006 (in progress)
CE Marking	In progress
UKCA Marking	In progress

Table 22: Compliance notes for substation grade

Certification	Notes
IEC 61850-3 Ed 2.0	<p>The SMP DA-3050 automation platform is a communication device designed to achieve the highest immunity required in power stations to the local, field and high voltage signal port connections. It can be installed in low, medium and high voltage substations, in any weather-protected unconditioned environment.</p> <p>It is designed to meet or to surpass IEC 61850-3 ed2.0 (exceptions apply). A class 2 is achieved with the Ethernet optical LC link.</p> <p>Due to the importance of selecting good cable quality EMC test were performed with EATON cables.</p> <p>The SMP DA-3050 automation platform compliance with the IEC 61850-3 standard was validated by an independent certified testing laboratory. The compliance test reports are available on demand.</p>
IEEE Std 1613™-2009 IEEE Std 1613a™-2011 IEEE Std 1613.1™-2013	<p>The SMP DA-3050 automation platform can be installed in Zone A&B. It is also designed to meet or to surpass IEEE Std 1613 requirements as Class 2 networking device for Ethernet fiber-optic LC connector communications (exceptions apply). SMP DA-3050 automation platform ensures error-free, uninterrupted communications required for Class 2 critical processes and protections.</p> <p>Due to the importance of selecting good cable quality, EMC test were performed with EATON cables.</p> <p>The SMP DA-3050 automation platform compliance with the IEEE 1613 standard was by an independent certified testing laboratory. The compliance test reports are available on demand.</p>
IEC 60255-1	<p>The SMP DA-3050 automation platform is designed to meet or surpasses the IEC 60255-1 requirements (exceptions apply). Per IEC 60255-26, the SMP DA-3050 automation platform is a command & control device and is compliant to be installed in Zone A & B. The compliance test reports are available on demand.</p>
cTUVus	<p>The SMP DA-3050 automation platform will be cTUVus marked. Once certified, it ensures the end user that the SMP DA-3050 automation platform is safe.</p> <p>The SMP DA-3050 automation platform cTUVus certification is undergoing validation by an independent certified testing laboratory. The marking reports will be available on demand.</p>

Type test details

This section presents all tests conducted on the SMP DA-3050 automation platform.

Important: The SMP DA-3050 automation platform is currently undergoing tests for the different specifications listed in this section. The values are subject to change until the testing phase has been completed.

Table 23: Type test details: common test

Common test		
Communication profile	Profile 2 (IEC) Profile 3 (IEEE)	<p>Simulating maximum communication load for all ports (Profile 2) Error-free Ethernet LC communications (Class 2) Analog values might change by maximum 2% of full scale values during tests. Analog ports of the Analog I/O module were tested with shielded cables.</p> <p>Note: The cellular modem was upheld in reset phase during all tests.</p>

Table 24: Type test details: IEC 61850-3 ed2 .0 (2013), Communication profile and Electromagnetic Compatibility (EMC)

Type test details : IEC 61850-3 ed2 .0 (2013)		
Electromagnetic Compatibility (EMC)		
Conducted emissions	CISPR32 (2015) A1 (2019) FCC part 15 subpart B (2021) ICES-003 (2016)	Class A 150 kHz—30 MHz
Radiated Emissions	CISPR32 (2015) A1 (2019) FCC part 15 subpart B (2021) ICES-003 (2016)	Class A 30 Mhz—9 GHz
Electrostatic Discharge Immunity	IEC 61000-4-2 (2008)	Contact: ± 6 kV Air: ± 8 kV
Radiated Electromagnetic Field Immunity	IEC 61000-4-3 (2020)	Frequency sweep: • 80 MHz—3 GHz: 20 V/m Spot frequencies: • 80 MHz, 160 MHz, 380 MHz, 450 MHz, 900 MHz, 1850 MHz, 2150 MHz: 10 V/m
Electrical Fast Transient Immunity	IEC 61000-4-4 (2012)	Power: ± 4 kV / 5 kHz and 100 kHz I/O ports: ± 4 kV / 5 kHz and 100 kHz Communication ports: ± 4 kV / 5 kHz and 100 kHz
Surge Immunity	EN 61000-4-5 (2014) A1 (2017)	Power: ± 2 kV L-PE / ± 1 kV L-L I/O ports: ± 4 kV Communication Ports (shielded lines): ± 4 kV
Conducted Immunity	IEC 61000-4-6 (2013)	All ports: 10 V Sweep frequency: 150 kHz to 80 MHz Spot frequencies: 27 MHz, 68 MHz

Table 24: Type test details: IEC 61850-3 ed2 .0 (2013), Communication profile and Electromagnetic Compatibility (EMC)

Type test details : IEC 61850-3 ed2 .0 (2013)		
Power Frequency Magnetic Field Immunity	IEC 61000-4-8 (2009)	Continuous field: • 100 A/m / 50 Hz & 60 Hz Short duration field: • 1000 A/m / 50 Hz & 60 Hz
Conducted Common Mode Disturbances in the Frequency Range 0Hz-150kHz	IEC 61000-4-16 (2015)	Continuous: 30 Vrms, 50 Hz & 60 Hz Short duration: 300 Vrms, 50 Hz & 60 Hz Variation 15 Hz – 150 Hz: level 4
Ripple on DC Input power port immunity test	IEC 61000-4-17 (1999) A1 (2002) A2 (2009)	% of nominal DC voltage: 10 % at 100 Hz & 120 Hz Test duration: 10 min
Damped Oscillatory Wave Immunity	IEC 61000-4-18 (2006) A1 (2010)	2.5 kV common mode 1 kV differential mode Oscillation Frequency : 1 MHz
Voltage Dips, Short Interruptions and Voltage Variation on DC Power Port Immunity	IEC 61000-4-29 (2000)	Voltage dips: • 40% Un during 100 ms ¹ • 70% Un during 100 ms ¹ Voltage short interruptions: • 0% Un during 0.5 s ¹ 1: With unit rebooting and self-recovering
Protective bonding resistance	IEC 61850-3 ed2.0 (2013)	At 20 A, R < 0.1 Ω

Table 25: Type test details: IEC 61850-3 ed2 .0 (2013), Climatic environment conditions

Type test details : IEC 61850-3 ed2 .0 (2013)		
Climatic environment conditions		
Dry heat & Operational Storage	IEC 60068-2-2 (2007) Test Bd, Bb	Bd 75 °C, 16 hr Operational, including 5 consecutive warm boots Bb 85 °C, 16 hr Storage
Cold Operational & Storage	IEC 60068-2-1 (2007) Test Ad, Ab	Ad -40 °C, 16 hr Operational, including 5 consecutive cold boots Ab -40 °C, 16 hr Storage
Damp Heat, Steady State	IEC 60068-2-78 (2001) Test Cab	40°C, 93%, 10 days
Damp Heat, Cyclic	IEC 60068-2-30 (2005) Test Db	40°C, 6 cycles (12 hr + 12 hr), variant 2 Lower temp 25 °C, 97% RH Upper temp 55 °C, 93% RH
Change of temperature	IEC 60068-2-14 (2009) Test Nb	-40 °C + 75 °C (-40 °F + 167 °F) 5 cycles, 1°C/min

Table 26: Type test details: IEC 61850-3 ed2 .0 (2013), Mechanical environmental conditions

Type test details : IEC 61850-3 ed2 .0 (2013)		
Mechanical environmental conditions		
Sinusoidal Vibration Endurance & Response	IEC 60255-21-1 (1988)	Endurance: 20 cycles, 1g, 10—150 Hz, 3 axes, Class 1 Response: 1 cycle, 0.5 g, 10—150 Hz, 3 axes, Class 1
Shock-Bump Endurance & Response	IEC 60255-21-2 (1988)	Withstand: 30 g, 11 ms, 3 pulses, 3 axes, Class 2 Response: 10 g, 11 ms, 3 pulses, 3 axes, Class 2 Bumps: 20 g, 16 ms, 1000 bumps, 3 axes, Class2
Sinusoidal Vibration - Seismic	IEC 60255-21-3 (1993)	Method A, Class 2 X = 7.5 mm (2 g), Y = 3.5 mm (1 g)

Table 27: Type test details: IEC 61850-3 ed2 .0 (2013), Safety

Type test details : IEC 61850-3 ed2 .0 (2013)		
Safety		
Product Safety requirements		The product SMP DA-3050 automation platform is undergoing certification for cTUVus on IEC 62368-1 for the safety requirement. A test report for IEC 61010-1 will also be available.
Dielectric test	IEC 61850-3 (2013) IEC 60255-27 (2013)	Power input: 1500 Vdc Ethernet ports and analog inputs: 1.5 kVrms Analog outputs: 1 kVrms Unmodulated IRIG-B input: 2 kVrms All relays and digital inputs: 2.5 kVrms
Impulse Withstand	IEC 61850-3 (2013) IEC 60255-27 (2013) IEC 61180 (2016)	Power input, Ethernet and analog ports: ± 2.5 kV ¹ Unmodulated IRIG-B, all relays and digital inputs: ± 4 kV ¹ 1: The standards specify ± 5 kV for the impulse test.
Protective bonding resistance	IEC 61850-3 (2013) IEC 60255-27 (2013)	At 20 A, $R < 0.1 \Omega$

Table 28: Type test details: IEEE 1613 (2009) + AMD (2011) + IEEE 1613 .1 (2013), Electromagnetic Compatibility (EMC)

Type test details : IEEE 1613 (2009) + AMD (2011) + IEEE 1613 .1 (2013)		
Electromagnetic Compatibility (EMC)		
Electrostatic Discharge Immunity	C37.90.3 (2001)	Contact: $\pm 2, \pm 4, \pm 8$ kV Air: $\pm 4, \pm 8, \pm 15$ kV

Table 28: Type test details: IEEE 1613 (2009) + AMD (2011) + IEEE 1613 .1 (2013), Electromagnetic Compatibility (EMC)

Type test details : IEEE 1613 (2009) + AMD (2011) + IEEE 1613 .1 (2013)		
Radiated Electromagnetic Field Immunity	C37.90.2 (2004)	Frequency sweep: <ul style="list-style-type: none"> • 80 MHz—1 GHz: 20 V/m • 1 GHz—2.7 GHz: 10 V/m Spot frequencies: <ul style="list-style-type: none"> • 80 MHz, 160 MHz, 450 MHz, 900 MHz: 20 V/m (AM) • 900 MHz 20 V/m (PM) • 900 MHz, 1.6 GHz & 3.8 GHz 10 V/m (AM) • 1.732 GHz, 1.8 GHz, 2.31GHz, 2.45 GHz, 5.8 GHz 8.5 V/m (PM)
SWC : Fast Transient Waveform	C37.90.1 (2002)	Power: ± 4 kV / 2.5 kHz I/O Ports: ± 4 kV / 2.5 KHz Communication Ports: ± 4 kV / 2.5 kHz
Surge Immunity	IEC 61000-4-5 (2014) A1 (2017)	Power: ± 2 kV L-PE / ± 1 kV L-L1 I/O ports: ± 4 kV Communication ports (shielded lines): ± 4 kV 1: IEEE std. 1613.1 (2013) specifies the surge immunity at level 4 rather than level 3 for power input.
Immunity to Conducted Disturbances, Induced by Radio-Frequency Fields	IEC 61000-4-6 (2013)	All ports: 10 V Sweep frequencies: 150 kHz to 80 MHz Spot frequencies: 27 MHz, 68 MHz
Power Frequency Magnetic Field Immunity	IEC 61000-4-8 (2009)	Continuous field: <ul style="list-style-type: none"> • 100 A/m / 50 Hz and 60 Hz Short duration field: <ul style="list-style-type: none"> • 1000 A/m / 50 Hz and 60 Hz
Damped Oscillatory Magnetic Field Immunity Test	IEC 61000-4-10 (2016)	Field Strength: 100 A/m Oscillation Frequency: 100 kHz and 1 MHz
Conducted Common Mode Disturbances in the Frequency Range 0 Hz—150 kHz	IEC 61000-4-16 (2015)	Continuous: 30 Vrms, 50 Hz and 60 Hz Short duration: 300 Vrms, 50 Hz and 60 Hz Variation 15 Hz—150 Hz: level 4
Ripple on DC Input Power Port Immunity test	IEC 61000-4-17 (1999) A1 (2002) A2 (2009)	% of nominal DC voltage: 5 % Test duration: 1 min
SWC : Oscillatory Waveform	C37.90.1 (2012)	2.5 kV common mode 2.5 kV differential mode Oscillation Frequency: 1 MHz
Impulse Voltage Withstand Test	IEC 60255-27 (2013)	Power input, Ethernet and analog ports: ± 2.5 kV ² Unmodulated IRIG-B input, all relays and digital inputs: ± 4 kV ² 2: IEEE std. 1613 (2009) specifies ± 5 kV rather than ± 4 kV for the impulse test.

Table 28: Type test details: IEEE 1613 (2009) + AMD (2011) + IEEE 1613 .1 (2013), Electromagnetic Compatibility (EMC)

Type test details : IEEE 1613 (2009) + AMD (2011) + IEEE 1613 .1 (2013)		
Dielectric Test	IEC 60255-5 (2000)	Power input: 1500 Vdc Ethernet ports and analog inputs: ± 1.5 kVrms Analog outputs: 1 kVrms Unmodulated IRIG-B input: 2 kVrms All relays and digital inputs: 2.5 kVrms

Table 29: Type test details: IEEE 1613 (2009) + AMD (2011) + IEEE 1613 .1 (2013), Climatic environment conditions

Type test details : IEEE 1613 (2009) + AMD (2011) + IEEE 1613 .1 (2013)		
Climatic environment conditions		
Dry heat & Operational Storage	IEC 60068-2-2 (2007) Test Bd, Bb	Bd 75°C, 16 hr Operational, including 5 consecutive warm boots Bb 85°C, 16 hr Storage
Cold Operational & Storage	IEC 60068-2-1 (2007) Test Ad, Ab	Ad -40°C, 16 hr Operational, including 5 consecutive cold boots Ab -40°C, 16 hr Storage
Damp Heat, Steady State	IEC 60068-2-78 (2001) Test Cab	40°C, 93%, 10 days

Table 30: Type test details: IEEE 1613 (2009) + AMD (2011) + IEEE 1613 .1 (2013), Mechanical environmental conditions

Type test details : IEEE 1613 (2009) + AMD (2011) + IEEE 1613 .1 (2013)		
Mechanical environmental conditions		
Sinusoidal Vibration Endurance & Response	IEC 60255-21-1 (1988)	Endurance: 20 cycles, 1 g, 10—150 Hz, 3 axes Response: 1 cycle, 0.5 g, 10—150 Hz, 3 axes
Shock-Withstand & Response	IEC 60255-21-2 (1988)	Withstand: 30 g, 11 ms, 3 pulses, 3 axes Response: 10 g, 11 ms, 3 pulses, 3 axes
Free fall	IEC 60068-2-31 (2008)	1 m with packaging

Table 31: Type test details: IEC 60255-1 series, Electromagnetic Compatibility (EMC)

Type test details : IEC 60255-26 (2013)		
Electromagnetic Compatibility (EMC)		
Conducted emission	CISPR32 A1 (2019) FCC part 15 subpart B (2021) ICES-003 (2016)	Class A 150 kHz—30 MHz
Radiated emission	CISPR32 FCC part 15 subpart B (2021) ICES-003 (2016)	Class A 30 MHz—9 GHz
Electrostatic Discharge Immunity	IEC 61000-4-2 (2008)	Contact: $\pm 2, \pm 4, \pm 6$ kV Air: $\pm 2, \pm 4, \pm 8$ kV
RF Electromagnetic Field Immunity test	IEC 61000-4-3 (2020)	Frequency sweep: <ul style="list-style-type: none"> 80 MHz—1 GHz: 10 V/m 1 GHz—2.7 GHz: 10 V/m Spot frequencies: <ul style="list-style-type: none"> 80 MHz, 160 MHz, 380 MHz, 450 MHz, 900 MHz, 1850 MHz, 2150 MHz: 10V/m
Electrical Fast Transient Immunity	IEC 61000-4-4 (2012)	Power: ± 4 kV / 5 kHz I/O Ports: ± 4 kV / 5 kHz Communication Ports: ± 4 kV / 5 kHz
Surge Immunity	IEC 61000-4-5 (2014) A1 (2017)	Power: $\pm 0.5, 1, 2$ kV L-PE / $\pm 0.5, 1$ kV L-L1 I/O ports: $\pm 0.5, 1, 2, 4$ kV L-PE / $\pm 0.5, 1, 2$ kV L-L Communication Ports (shielded lines): $\pm 0.5, 1, 2, 4$ kV 1: IEC 60255-26 standard specifies the surge immunity to be at level 4 rather than level 3 for power input.
Immunity to Conducted Disturbances, Induced by Radio-Frequency Fields	IEC 61000-4-6 (2013)	All ports: 10 V Sweep frequencies: 150 kHz to 80 MHz Spot frequencies: 27 MHz, 68 MHz
Power Frequency Magnetic Field Immunity	IEC 61000-4-8 (2009)	Continuous field: <ul style="list-style-type: none"> 30 A/m / 50 Hz and 60 Hz Short duration field: <ul style="list-style-type: none"> 1000 A/m / 50 Hz and 60 Hz
Conducted Common Mode Disturbances in the Frequency Range 0Hz—150kHz	IEC 61000-4-16 (2015)	Continuous: 30 Vrms, 50 Hz and 60 Hz Short duration: 300 Vrms, 50 Hz and 60 Hz Variation 15 Hz—150 Hz: level 4
Ripple on DC Input Power Port Immunity	IEC 61000-4-17 (1999) A1 (2002) A2 (2009)	% of nominal DC voltage: 15 % @ 100 Hz and 120 Hz Test duration: 1 min

Table 31: Type test details: IEC 60255-1 series, Electromagnetic Compatibility (EMC)

Type test details : IEC 60255-26 (2013)		
Damped Oscillatory Wave Immunity	IEC 61000-4-18 (2006) A1 (2010)	2.5 kV common mode 2.5 kV differential mode Oscillation Frequency: 1 MHz
Voltage Dips, Short Interruptions and Voltage Variation on DC Power Port Immunity	IEC 61000-4-29 (2000)	Voltage dips: <ul style="list-style-type: none"> • 40% Un during 200 ms • 70% Un during 500 ms • 0% Un during 10 ms² Voltage interruptions: <ul style="list-style-type: none"> • 0% Un during 5s 2: Criteria A for the 0% voltage dips during 10 ms voltage dip can be only achieved at 48V operation.
Gradual shut-down/start-up for DC power supply	IEC 60255-26 (2013)	100% Un to 0 V during 60 seconds 0 V during 5 minutes 0 V to 100% Un during 60 seconds

Table 32: Type test details: IEC 60255-1 series, Climatic environment conditions

Type test details : IEC 60255-1 (2022)		
Climatic environment conditions		
Dry heat & Operational Storage	IEC 60068-2-2 (2007) Test Bd, Bb	Bd 75 °C, 16 hr Operational, including 5 consecutive warm boots Bb 85 °C, 16 hr Storage
Cold Operational & Storage	IEC 60068-2-1 (2007) Test Ad, Ab	Ad -40 °C, 16 hr Operational, including 5 consecutive cold boots Ab -40 °C, 16 hr Storage
Damp Heat, Steady State	IEC 60068-2-78 (2012) Test Cab	40 °C, 93%, 10 days
Damp Heat, Cyclic	IEC 60068-2-30 (2005) Test Db	40°C, 6 cycles (12 hr + 12 hr) Lower temp 25 °C, 97% RH Upper temp 55 °C, 93% RH
Change of temperature	IEC 60068-2-14 (2009) Test Nb	-40 °C +75 °C (40 °F + 167 °F) 5 cycles, 1 °C/min

Table 33: Type test details: IEC 60255-1 series, Mechanical environmental conditions

Type test details : IEC 60255-1 (2022)		
Mechanical environmental conditions		
Sinusoidal Vibration Endurance & Response	IEC 60255-21-1 (1988)	Endurance: 20 cycles, 1 g, 10—150 Hz, 3 axes, Class 1 Response: 1 cycle, 0.5 g, 10—150 Hz, 3 axes, Class 1
Shock–Withstand & Response Bump test	IEC 60255-21-2 (1988)	Withstand: 30 g, 11 ms, 3 pulses, 3 axes, Class 2 Response: 10 g, 11 ms, 3 pulses, 3 axes, Class 2 Bumps: 20 g, 16 ms, 1000 bumps, 3 axes, Class 2
Seismic test	IEC 60255-21-3 (1993)	Method A, Class 2 X = 7.5 mm (2 g) Y = 3.5 mm (1 g)

Table 34: Type test details: IEC 60255-1 series, Safety

Type test details : IEC 60255-27 (2013)		
Safety		
Product Safety requirements		The product SMP DA-3050 automation platform is undergoing certification for cTUVus on IEC 62368-1 for the safety requirements. A test report for IEC 61010-1 will also be available.
Dielectric test	IEC 60255-27 (2013)	Power input: 1500 Vdc Ethernet ports and analog inputs: 1.5 kVrms analog outputs: 1 kVrms Unmodulated IRIG-B input: 2 kVrms All relays: 2.5 kVrms
Impulse Withstand	IEC 60255-27 (2013) IEC 61180 (2016)	Power input, Ethernet and analog ports: $\pm 2,5$ kV ¹ Unmodulated IRIG-B input, all relays: ± 4 kV ¹ 1: IEC 60255-27 standard specifies ± 5 kV rather than ± 4 kV for the impulse test.
Protective bonding resistance	IEC 60255-27 (2013)	At 20 A, $R < 0.1 \Omega$

The SMP DA-3050 automation platform is rugged, reliable, and tailored to our customer's requirements. It is easy to setup and use. Eaton has decades of experience in substation-grade platforms design for grid automation systems, making our SMP DA-3050 automation platform a product that utilities can rely on.

Temperature derating

To be compliant with the IEC 61010-1 certification, the SMP DA-3050 automation platform can be used within the temperature range that is function of the total power dissipated in the unit, as described below. According to the standard, the SMP DA-3050 automation platform can support operating temperatures between -40 °C to 75 °C (40 °F to +167 °F).

Due to the different models and I/O configurations, Eaton provides a Microsoft Excel™ calculator tool to enable our customers to easily calculate the total power dissipated in the device. The following table displays the maximum operational temperature allowed according to the total power dissipation in the device or to a specific configuration.

Table 35: Maximum operational temperature allowed for the device according to different factors

Total power dissipated in the unit (W)	Specific configuration	Maximum operational temperature allowed (°C)
≤ 6.1	n/a	70 (to comply with the cTUVus marking certification)
> 6.2 and < 7	n/a	65
> 7 and < 10	n/a	60
> 10	n/a	55
n/a	HMI display* connected	60
n/a	SFP transceiver present	65

Following are some captures taken from the calculator tool for configurations with a maximum total power dissipation in the unit, one for each model.

	# Inputs/Outputs	Power dissipation (W)
SMP DA-3050	Base	5.1
SFP-based Ethernet module present	1	0.8
Communication COM1, COM2, IRIG-B	1	0.3
OUT1-OUT2	2	
Average current OUT1-OUT2 (max value 8 A)	8	0.748
	Total:	6.948

Figure 15: Maximum power dissipation in the SMP DA-3050 model

	# Inputs/Outputs	Power dissipation (W)
SMP DA-3051	Base	5.1
SFP-based Ethernet module present	1	0.8
Communication COM1, COM2, IRIG-B	1	0.3
DI @ 24 V (max # of DI = 8)	0	0
DI @ 48 V (max # of DI = 8)	0	0
DI @ 125 V (max # of DI = 8)	8	2.8544
OUT1-OUT2	2	
Average current OUT1-OUT2 (max value 8 A)	8	0.748
DO (max # of DO = 4)	4	
Average current per DO (max value 8 A)	8	1.496
	Total:	11.2984

Figure 16: Maximum power dissipation in the SMP DA-3051 model

	# Inputs/Outputs	Power dissipation (W)
SMP DA-3052	Base	7.1
SFP transceiver present	1	0.8
Communication COM1, COM2, IRIG-B	1	0.3
DI @ 24 V (max # of DI = 16)	0	0
DI @ 48 V (max # of DI = 16)	0	0
DI @ 125 V (max # of DI = 16)	16	5.7088
OUT1-OUT2	2	
Average current OUT1-OUT2 (max value 8 A)	8	0.748
DO (max # of DO = 8)	8	
Average current per DO (max value 8 A)	8	2.992
AO voltage mode (max # of AO = 4)	0	0
AO current mode (max # of AO = 4)	4	1.8
AI current mode only (max # of AI = 4)	4	0.2
	Total:	19.6488

Figure 17: Maximum power dissipation in the SMP DA-3052 model

	# Inputs/Outputs	Power dissipation (W)
SMP DA-3053	Base	5.8
SFP transceiver present	1	0.8
Communication COM1, COM2, IRIG-B	1	0.3
DI @ 24 V (max # of DI = 24)	0	0
DI @ 48 V (max # of DI = 24)	0	0
DI @ 125 V (max # of DI = 24)	24	8.5632
OUT1-OUT2	2	
Average current OUT1-OUT2 (max value 8 A)	8	0.748
DO (max # of DO = 12)	12	
Average current per DO (max value 8 A)	8	4.488
	Total:	20.6992

Figure 18: Maximum power dissipation in the SMP DA-3053 model

Dimension drawings

The following images show the dimensions of the SMP DA-3050 automation platform with different I/O module options. The dimensions of the optional HMI display are also shown.

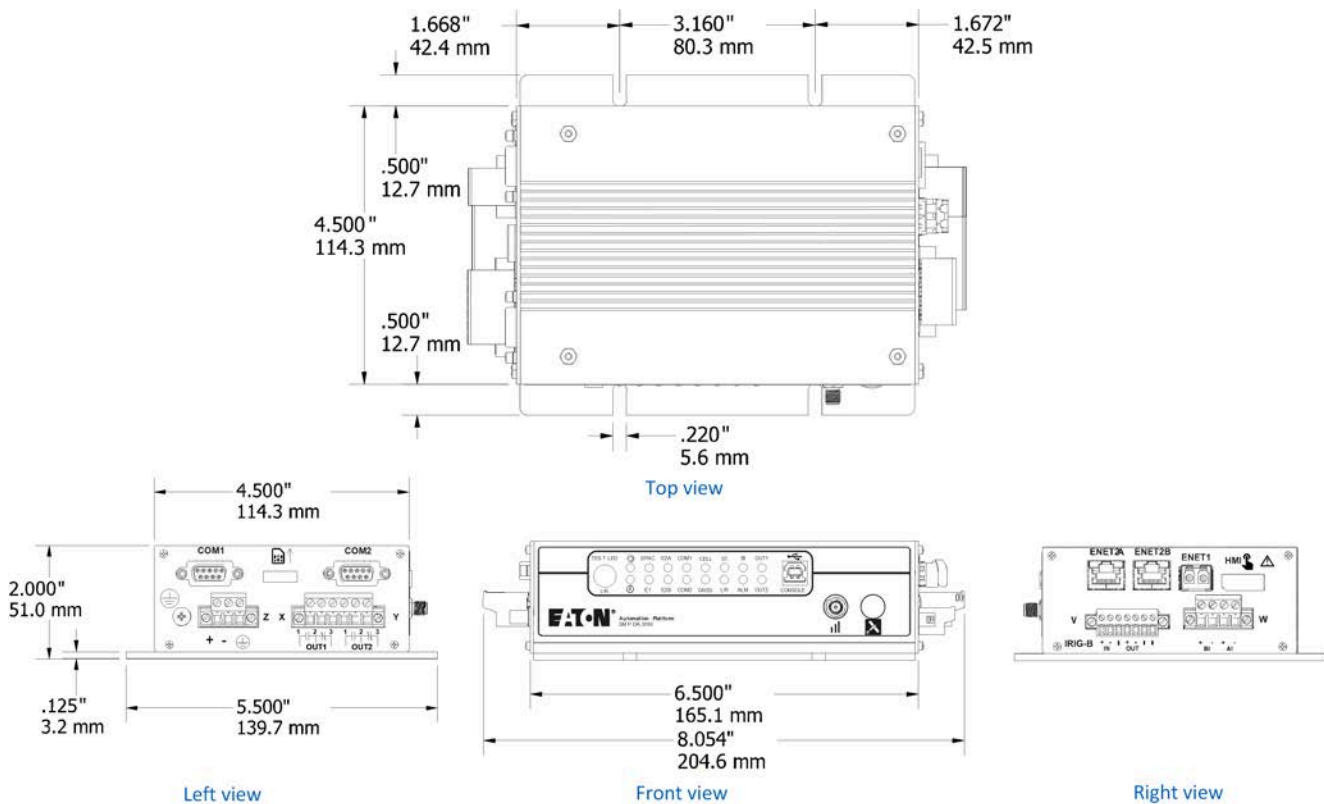
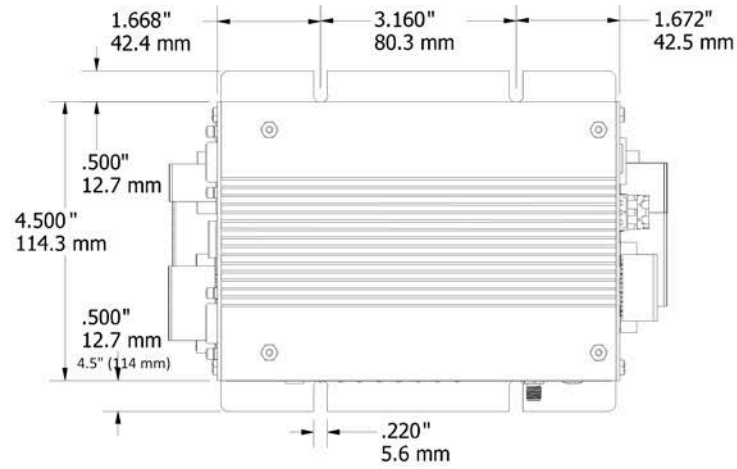
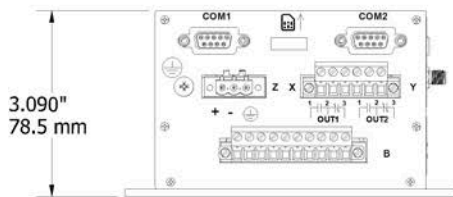

Figure 19: Dimensions of the SMP DA-3050 model — all views



Top view



Left view

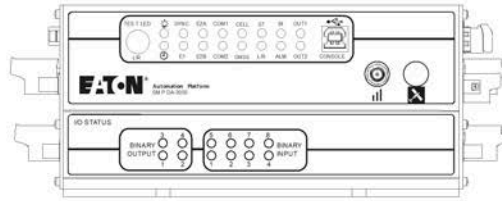

Front view

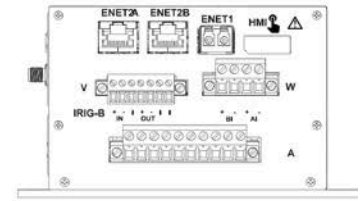

Right view

Figure 20: Dimensions of the SMP DA-3051 model — all views

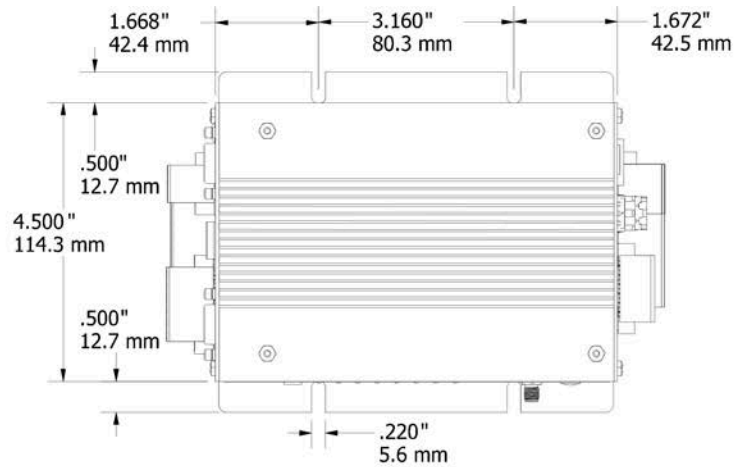

Top view

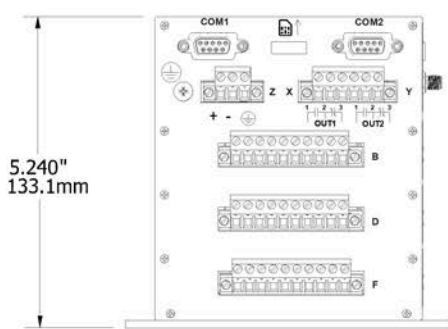

Left view

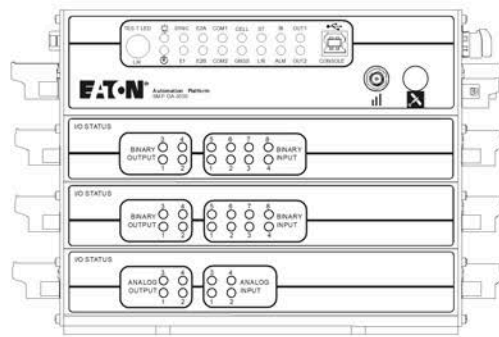

Front view

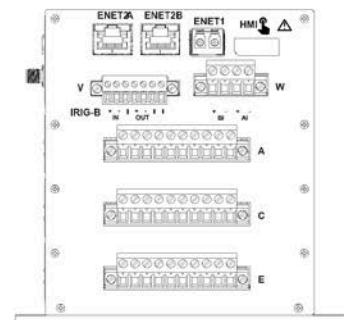

Right view

Figure 21: Dimensions of the SMP DA-3052 (shown) and SMP DA-3053 models — all views

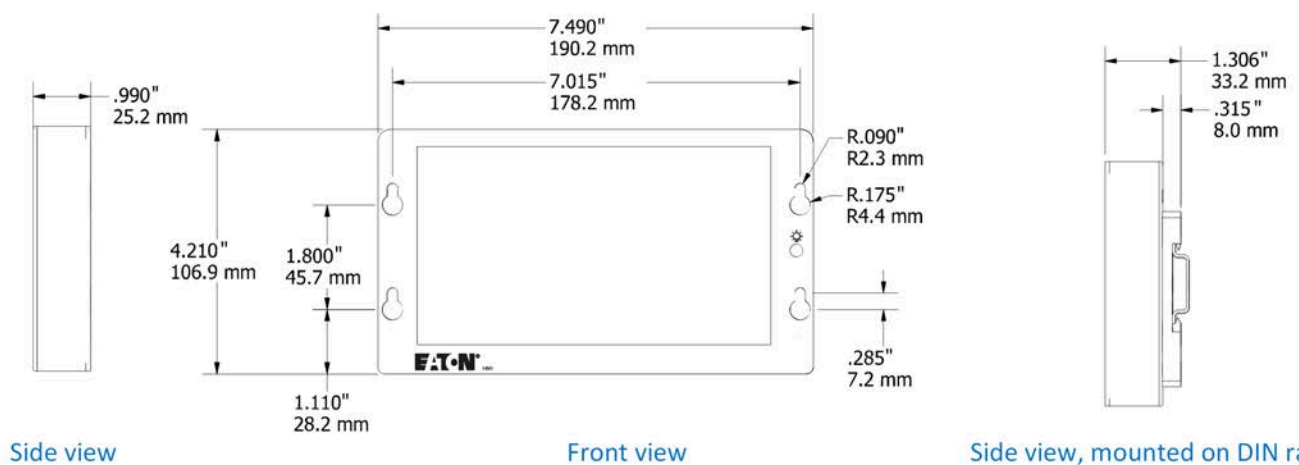

Side view

Front view

Side view, mounted on DIN rail

Figure 22: Dimensions of Eaton's HMI display*

Mounting options

The following images show different mounting option for the SMP DA-3050 automation platform, including mounting options with Eaton's HMI display.

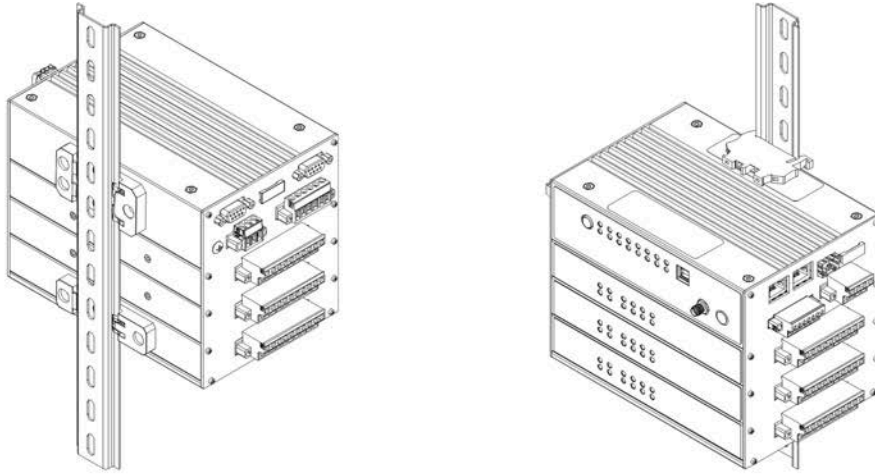

SMP-DA-3050 with three I/O modules mounted on DIN rail, rear/left side view and front/right side view

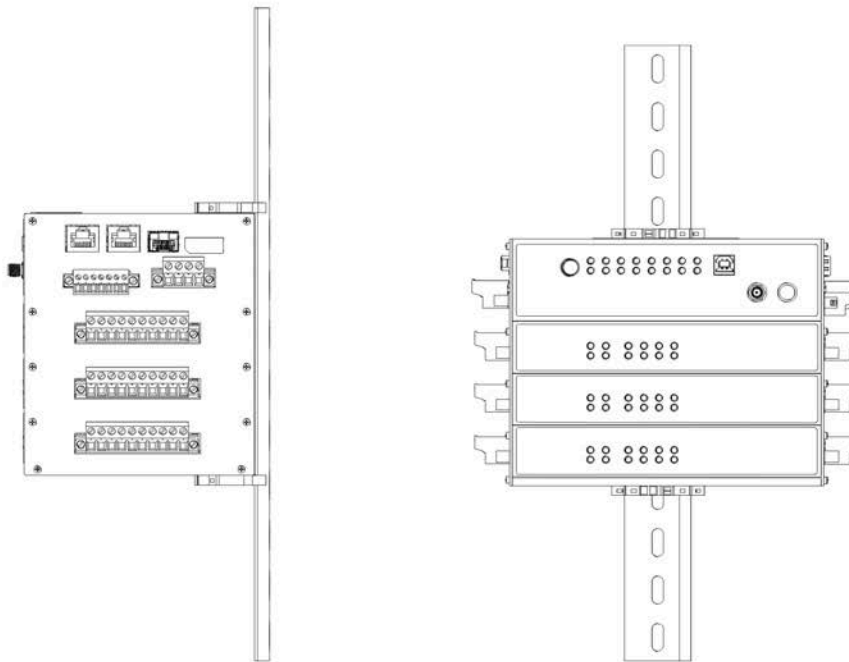

SMP-DA-3050 mounted on DIN rail, left view and front view

Figure 23: Mounting the SMP DA-3050 on DIN rail

Note: The stoppers are not shown on the top left image, they should however be installed.

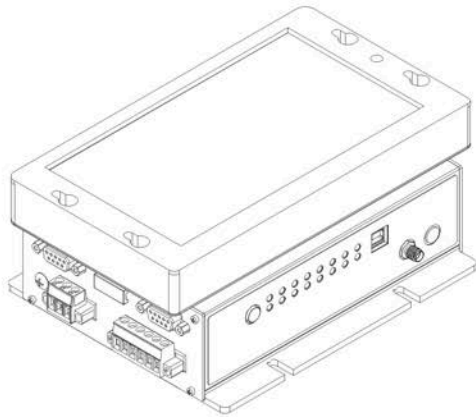

HMI display mounted on top of SMP-DA-3050, full length

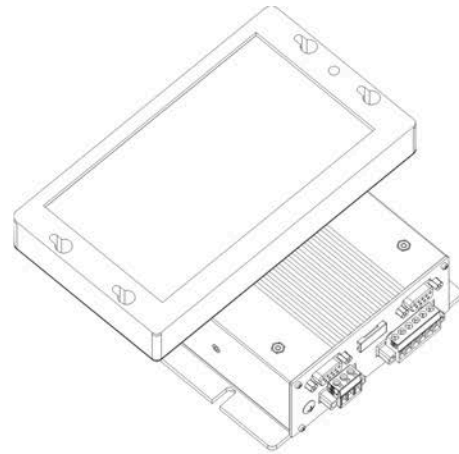

HMI display mounted on top of SMP-DA-3050, perpendicular



HMI display mounted on DIN rail, full length

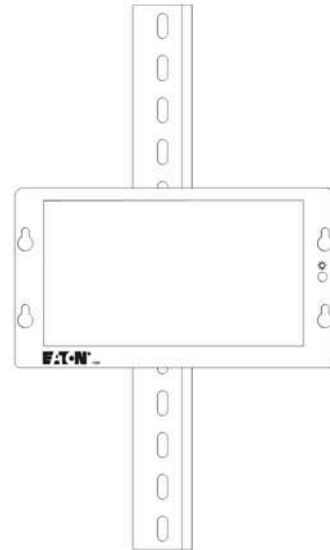

HMI display mounted on DIN rail, perpendicular

Figure 24: Mounting the HMI display*

Ordering information

A complete SMP DA-3050 automation platform is defined by its hardware components, its software features and finally the protocols components it includes. This section helps you define all these components and features. Additionally, several tables are listing the available accessories to complement the SMP DA-3050 automation platform.

Ordering information - System configuration chart

First the hardware components are defined using the system configuration chart which is presented in the following table.

Note: Features marked with *: You cannot order those features yet. However, those features are coming soon.

Table 36: System configuration chart

Description: SMP	123	4	5	6	7	8	9	10-11	12	13	14	15-16	17-18
Family													
SMP Distribution Automation	DA3												
Controller - Environmental Option													
I/Os controller only - No conformal coating		0											
I/Os controller only -With conformal coating Note: Call an Eaton representative if you want conformal coating.		C											
Controller - Model													
SMP DA-3050 platform (I/Os + controller): 1 GB of RAM I/Os: 2 x DO std, 1 x DI std, 1 x AI			5										
SMP DA-3050 platform (I/Os + controller); 4 GB of RAM I/Os: 2 x DO std, 1 x DI std, 1 x AI			7										
Controller - Additional I/O options Note: DI levels are software selectable and AI/AO levels are externally configurable.													
None				0									
8DI, 4DO (SMP DA3051 model, one I/O module)				1									
16DI, 8DO, 4AI, 4AO (SMP DA-3052 model, three I/O modules)				2									
24DI, 12DO (SMP DA-3053 model, three I/O modules)				3									
Controller - Wireless option*													
None					0								
Cellular modem without antenna*					1*								
Cellular modem with antenna and 1m cable*					2*								

Table 36: System configuration chart

Description: SMP	123	4	5	6	7	8	9	10-11	12	13	14	15-16	17-18
Controller - Ethernet option													
2x RJ45 10/100 Base-T ; No SFP (2x downstream switch)						3							
2x RJ45 10/100 Base-T; 1x SFP 1000B-LX, 1310 nm, 10 km (2x downstream switch, 1 x upstream)						4							
2x RJ45 10/100 Base-T; 1x SFP 1000B-LX, 1310 nm, 40 km (2x downstream switch, 1 x upstream)						5							
2x RJ45 10/100 Base-T; 1x SFP 1000B-LX, 850 nm, 550 m (2x downstream switch, 1 x upstream)						6							
2x RJ45 10/100 Base-T; 1x SFP 100B-FX, 1310 nm, 2 km (2x downstream switch, 1 x upstream)						7							
2x RJ45 10/100 Base-T; 1x SFP 10/100/1000B-T, RJ45* (2x downstream switch, 1 x upstream)						8*							
Controller - Mechanical													
None							0						
DIN-rail installation kit							1						
Wall-mount installation kit							2						
Rack-mount installation kit							3						
IED													
None								00					
Enclosure													
None									0				
Enclosure mounting													
None										0			
Power supply													
Internal 24—48 Vdc - No external power supply											0		
Internal 12—24 Vdc - No external power supply											1		

Table 36: System configuration chart

Description: SMP	123	4	5	6	7	8	9	10-11	12	13	14	15-16	17-18
External 85—264 Vac, 90—350 Vdc (Internal 24—48 Vdc included) DIN rail-mount											A		
External Universal 125 V to 24 Vdc (Internal 24—48 Vdc included) (lab only, not for production)											Y		
Accessories													
None												00	
HMI display* for Eaton devices with 0.3m cable												04*	
HMI display* for Eaton devices with 1.0 m cable												08*	
Communications													
None													00

Ordering information - Software configuration chart

The SMP DA-3050 includes several software features which are standard (free of charge); additionally, some features are optional and can be purchased. These software features are listed and described in Table 38 on page 44: Software features. You can order the software features using the following Software configuration chart table.

The SMP DA-3050 communicates with control center(s) and IEDs using specific protocols; all supported protocols are included in your license. The supported protocols are listed in Table 39 on page 46: Information on supported protocols.

Note: Features marked with *: You cannot order those features yet. However, those features are coming soon.

Table 37: Software configuration chart

Description	T	123	4	5	6	7	8	9	10	11	12	13	14	15	16
Type of configuration chart															
Software	SW														
Platform															
DA-3050		305													
Protocol package															
Note: All supported protocols are included in the license, you don't have to select a protocol package.															
None			0												
Additional Client protocol															
None				0											

Table 37: Software configuration chart

Description	T	123	4	5	6	7	8	9	10	11	12	13	14	15	16
Additional Server protocol															
None					0										
Options package															
None						0									
Basic options															
None							0								
HMI															
None								0							
Operational HMI lite Note: Web-based diagram* capabilities will be included when available.								D							
Operational HMI*								E*							
SoftPLC support*															
None									0						
SoftPLC engine (CODESYS)*									C*						
Redundancy support*															
None										0					
Redundancy*										B*					
Additional IEDs															
None											0				
Up to 16 IEDs											O				
Up to 32 IEDs											P				
Up to 64 IEDs											Q				
Additional tags															
None												0			
5,000 additional tags (points)												E			
10,000 additional tags (points)												F			
15,000 additional tags (points)												G			
Additional Control Centers															
None													0		

Table 37: Software configuration chart

Description	T	123	4	5	6	7	8	9	10	11	12	13	14	15	16
Up to 8 control centers													N		
Up to 16 control centers													M		
License															
Default															0
Demo license (6 months)															A
Reserved															
Default															0

Information on software features

Table 38: Software features

Software feature	Standard feature	Optional feature (with part number)	Description
Automation Functions	Included		Comprehensive set of logic and group operations
Secure web server <ul style="list-style-type: none"> • Communication dashboard • System dashboard • REST API 	Included		The SMP Gateway HMI can be accessed remotely using the integrated secure web server of the SMP Device and your Internet web browser. The integrated web server also allows access to the automation platform via the SMP REST API which is included in the software package.
Syslog	Included		The Syslog feature is used for remote log storage.
Sequence-of-events (SOE) Recorder	Included		Adds Sequence of Event capabilities to the SMP automation platform. Any binary points in the internal database can be used in the SOE. The events are stored in the non-volatile memory.
Operational HMI*			Provides diagram capabilities and alarms management to the SMP Device. Works remotely (web-based) and locally (requires external touch-screen or monitor and mouse).
Operational HMI lite Note: web-based diagram* capabilities will be included when available.		Use the software configuration tool to order it	Provides web-based diagram* capabilities and alarms management.
Secure remote access* (Passthrough)		Coming soon	Used to establish a transparent connection between programs running on a PC and any device connected to the SMP automation platform.

Table 38: Software features

Software feature	Standard feature	Optional feature (with part number)	Description
Redundancy support*		Coming soon	<p>Provides the capability to group two SMP DA-3050 in a redundant configuration. The standby automation platform automatically takes over if the main one fails. Also gives access to the Redundancy Dashboard of the Secure web server.</p> <p>How to order:</p> <p>When the Redundancy support is ordered, two identical automation platforms must be available or ordered using the same hardware part number for the two devices. Additionally, the software features must also be identical on both automation platforms and a single license for these options must be ordered for both devices.</p> <p>Example of an order (assuming that the customer has no SMP DA-3050 available):</p> <ul style="list-style-type: none"> • 2 x SMPDA305204000004 (two (2) identical SMP DA-3050) • 1 x SW30500000D0BPEN00 <ul style="list-style-type: none"> - Operational HMI lite - Redundancy support - Up to 32 IEDs - 5,000 additional Tags - Up to 8 Control Centers - Default license
SoftPLC engine* (CODESYS)		Coming soon	Provides the automation platform with the capability to run automation scripts developed with the CODESYS IEC 61131-3 workbench.
SoftPLC workbench, Linux-based (CODESYS IEC61131-3)*		Coming soon	<p>A powerful Linux-based workbench used to create automation scripts for the SMP Gateway automation platform, using any of the five IEC 61131-3 supported languages.</p> <p>This software application run on a PC and must be purchased only once, independently of the number of SMP automation platforms running the script.</p>
SNMP Agent*		Coming soon	<p>Allows an SNMP manager to poll the SMP DA-3050 for statistics, link-up alarms, link-down alarms, SMP reset alarms.</p> <p>Note: Supports SMP reset and statistic reset.</p>

Information on supported protocols

Table 39: Information on supported protocols

Protocol	Available as Client instance	Available as Server instance	Communication link/Additional information
IEEE 1815-2012 DNP3	Yes	Yes	Serial, TCP/IP, UDP
Secure Authentication v5 for DNP3	Yes*	Yes*	Requires the DNP3 protocol
IEC 61850 Ed.2	Yes*	No	TCP/IP
IEC 61850 GOOSE	Yes	Yes	Messages transmit/receive (publisher/subscriber)
IEC 60870-5 104	Yes*	Yes	TCP/IP
IEC 60870-5 101	Yes*	Yes*	Serial
Modbus	Yes	Yes*	RTU, TCP/IP
OPC UA	Yes*	Yes*	TCP/IP

Accessories and cables

Table 40: Accessories

Part number	Description
ANT-CEL-01-0100	Cellular antenna with cable - 1m (manufacturer: Taoglas)
SMP-SFP-FB-1011	SFP transceiver: 1000BASE-LX (LC connector), 1310 nm, Single mode fiber, 10 km range
SMP-SFP-FB-1012	SFP transceiver: 1000BASE-LX (LC connector), 1310 nm, Single mode fiber, 40 km range
SMP-SFP-FB-1013	SFP transceiver: 1000Base-SX (LC connector), 850 nm, Multimode fiber, 550 m range
SMP-SFP-FB-1014	SFP transceiver: 100-FX (LC), 1310 nm, Multimode fiber, 2 km
SMP-SFP-CO-1011	SFP transceiver: 10/100/1000BASE-T (RJ45 connector)
SMP-HMI-1001	HMI display for Eaton devices
SMP-HMI-1C01	HMI display for Eaton devices, with coating
SMP-HMI-CBL030	Cable for HMI display, 0.3 m
SMP-HMI-CBL100	Cable for HMI display, 1.0 m
SMP-MTGDIN-DA-3000	DA-3000 DIN rail-mounting installation bracket kit
SMP-MTGWM-DA-3000	DA-3000 wall-mounting installation bracket kit
SMP-MTGRM-DA-3000	SMP DA-3000 Rack-mount installation kit
SMP-PSU-2002	External power supply: IN: 85—264 Vac, 90—350 Vdc, OUT: 24 Vdc 3.5 A, DIN rail-mount
SMP-PSU-2005	External power supply: IN: 9—36 Vdc; OUT: 24 Vdc 2.5 A, DIN rail-mount
SMP-PSU-2006	External power supply: IN: Universal 125 V; OUT: 24 Vdc Lab only, not for production Wall plug adapter
600AB0008R	Replacement USB Cable, Shielded Note: For USB Console port

Eaton
1000 Eaton Boulevard
Cleveland, OH 44122
United States
Eaton.com

Eaton's Power Systems Division
2300 Badger Drive
Waukesha, WI 53188
United States
Eaton.com/smartgrid

© 2023 Eaton
All Rights Reserved
Printed in USA
Publication No. CA912016EN
October 2023

Eaton is a registered trademark.

All other trademarks are property of their
respective owners.

For Eaton's product information,
call 1-877-277-4636 or visit:
www.eaton.com/smartgrid

